

PIPELINE INSULATORS

2.5.1

FABRICATED STEEL INSULATORS

BAC FABRICATED STEEL INSULATORS will safely support carrier pipes of any diameter in steel, cast iron or concrete casings and can, if required, be designed to accurately centralise the pipe within the casings. The insulator is fabricated from high grade 14 SWG steel (0.074", 1.88 mm) and is either coated with high grade PVC to a thickness of approximately 0.40 mm (0.015") or zinc plated dependent upon customers requirement. Skids of high density polyethylene are used and these are solid injection mouldings capable of withstanding in excess of 25 tonnes and temperatures of 120°C (250°F). Each skid is fixed to the insulator by two welded studs. The skids will suit most types of applications and load requirement, and are available in two thicknesses, 19 mm and 38 mm. When there is a large differential between carrier pipe and sleeve size, insulators with skid risers are supplied to either accurately centralise the pipe within the casing or radius to customers requirements. The skid riser is fabricated from 10 SWG steel and has supporting gussets on 600 mm carrier pipe and over.

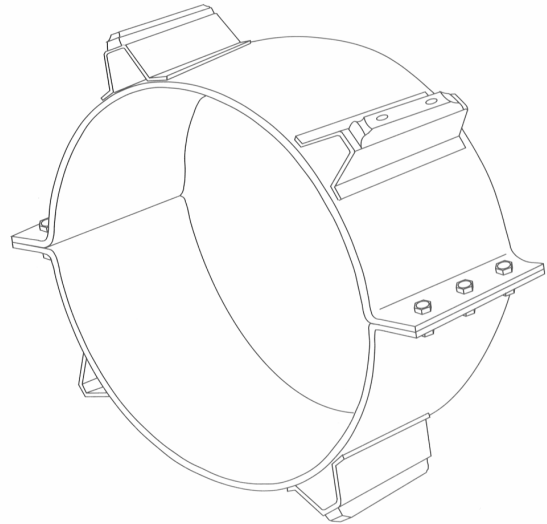

BAC FABRICATED STEEL INSULATORS provide triple electrical insulation between the carrier pipe and sleeve:

- (a) Pipe Coating
- plus (b) High duty plastic coating of all steel components (where applicable).
- plus (c) Insulated skids.

BAC FABRICATED STEEL INSULATORS are available in any standard size up to 1050 mm diameter and can be made to customers special requirements in greater diameters if required. For ease and speed of installation the insulators come in two semi-circular halves which are clamped together by zinc plated or galvanised bolts which are supplied with each insulator.

PLASTIC INSULATORS FOR PIPELINES

2.5.1

BAC INSULATORS made from high density polyethylene are universally applicable to the installation of pipelines when the carrier pipe runs inside a casing.

For this comprehensive range of application the plastic insulators offer a number of advantages such as:

- very low coefficient of friction allowing it to slide easily inside casing;
- flexibility of material avoids damage to the protective coating and insulation of the pipes;
- concentric support of the carrier pipe within the casing due to an extensive range of skid heights from $\frac{5}{8}$ " (16 mm) to $3\frac{9}{16}$ " (90 mm);
- outstanding electrical properties of the material satisfy cathodic protection requirements.

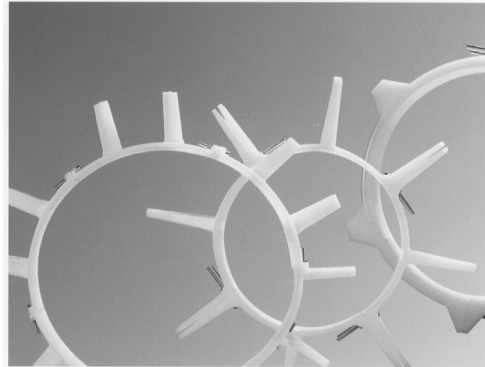

BAC PLASTIC INSULATORS are available for every pipe size and with various skid heights for all pipe materials such as steel, cast iron, clay, asbestos cement, concrete or plastic pipes.

Type PA Plastic Insulators

Type PA plastic insulators are available for pipe diameters from 2" (50 mm) to 12" (300 mm). The PA insulators consist of two segments. The necessary cadmium plated screws and nuts are included. Specially designed screws and nuts in nylon are available on request. The type code for the PA insulators includes the data for pipe diameter in inches and the skid height in mm. The maximum skid height is obtained by deducting the carrier pipe O.D. from the casing pipe I.D. divided by 2; the actual dimensions must take into account the thickness of any coating on the carrier pipe. For insulators from 14" (350 mm) nominal size up refer to type AZ or type MA.

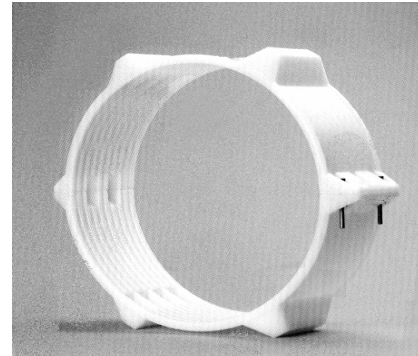

Type AZ Plastic Insulators

Insulators of segments type AZ are used for pipe diameters from 4" (100 mm) to 12" (300 mm) nominal size. AZ insulators are assembled from several segments. The number of segments required for each insulator is determined by the carrier diameter. Available skid heights from $\frac{5}{8}$ " (16 mm) to $3\frac{9}{16}$ " (90 mm). The necessary cadmium plated screws and nuts are included. Specially designed screws and nuts in nylon are available on request.

Advantages offered by this type of insulator are:

- suitability to a wide range of carrier pipe diameters. Particularly important for clay, asbestos cement, concrete or plastic pipes.
- only two segment sizes are required to cover the full range, thus reducing the problem of stock levels.

For insulators from 14" (350 mm) nominal size refer to type MA.

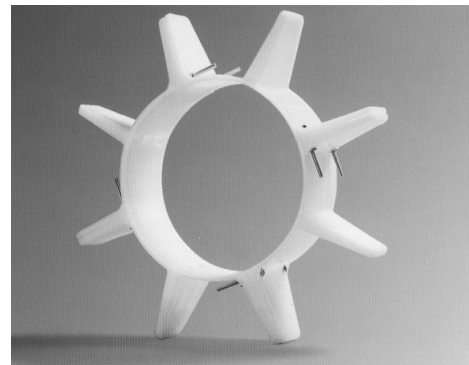

Type MA Plastic Insulators

Insulator type MA are available to suit pipe diameters from 14" (350 mm) to 48" (1200 mm). MA insulators are assembled from two basic segments (ref. MA and MA/2). Cadmium plated screws and nuts are included. Specially designed screws and nuts in nylon are available on request. skid height may be selected from a range of 4 standards - 25, 36, 50 and 75 mm.

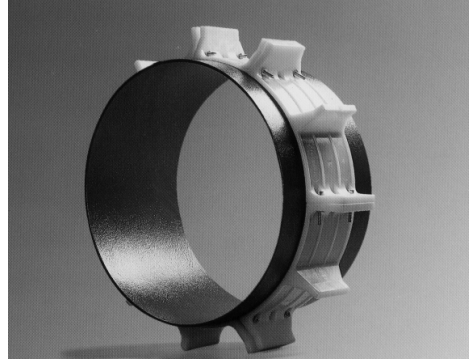

Type NMV Insulator Segments

Especially designed for the requirements of cathodic protection. Insulator ring without metallic parts. Connection of the segments by means of plastic-wedges (see drawing).

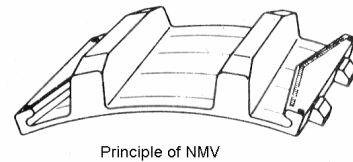
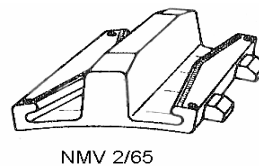
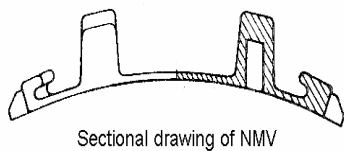
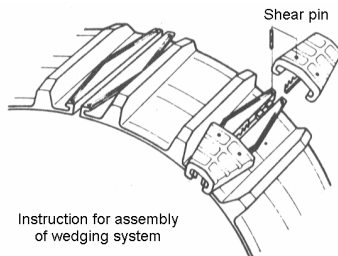
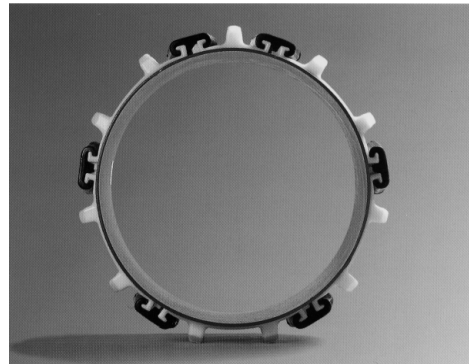

Optional Items 2.5.1

Bolting: Screws and nuts in nylon available on request.

Piggyback: All insulators can be supplied with polyethylene support for cable conduit. conduit is strapped in position with stainless banding located by a groove in the support.

Self-adhesive lining: This lining remarkably increased the adhesion of the insulators to the smooth surface of PVC, PE or PE-coated steel pipes.

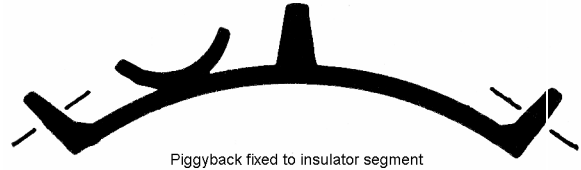

Material

BAC insulators are injection moulded from high density natural colour polyethylene and are suitable for a maximum working temperature up to 80°C (176°F).

High density polyethylene has outstanding sliding properties and a remarkably low coefficient of friction compared with other materials. This is important to easy insertion of the carrier pipe. Flexibility of the insulators ensures conformability and uniform loading on the pipe coating.

Spacing between plastic insulators depends largely on the bearing quality of the pipe coating and the flexibility of the pipe. As a general rule, the following spacing is recommended:

Pipe dia up to 12" (300 mm)	max. 3 m (10')
Pipe dia from 14" (350 mm) to 24" (600 mm)	max. 2m (7')
Pipe dia from 26" (650 mm) and larger	max 1.5 m (5')

For plastic pipes, spacing should be reduced to max 1.5 m (5'). Always install one insulator or cradle within 15 cm (6") of each end of any casing, regardless of size of casing and carrier pipe or type of insulator used. The above spacings apply to conventional pipelines. An exact determination of spacing depends on the following factors: pipe dia/pipe wall thickness/medium gas or liquid/temperature/coefficient of friction on casing material/length of casing. All insulators regardless of the type or size, must be securely fastened around the pipe.

Note: All **BAC insulators** are supplied complete with the necessary fixing screws and nuts.

Special Types for High Temperatures

All insulators are also available on request in a special version for high temperature ranges. BAC insulators manufactured from glass reinforced resin are suitable for

- hot water pipelines
- steam pipelines
- district heating systems up to 230°C (446°F)