

Portable Pin Brazing Equipment

EASYBOND MKII



The Heavy duty **Easybond MKII** unit is suitable for all types of installation and maintenance work. It is primarily for the user who needs a simple, rugged and low cost machine. The unit is portable, easy to maintain and transport. The brazing process is controlled by means of the fuse wire on the brazing pin. The capacity is approx. 30 brazes (including surface preparation) with the smallest type of brazing pin, and it can easily be increased by a battery charger mounted in a vehicle, the batteries being charged up during transportation between workplaces. When alternating between charging and brazing it is possible to increase the capacity up to 5 times during a working day. The batteries are high performance Gel type and sealed to prevent acid spill.

Description and Part No. Easybond

Weights:

Easybond MKII System Complete	273 199 5660	Easybond MKII unit complete	29.7 kg
Easybond MKII Power control Unit*	273 199 5610	Easybond MKII unit complete	18.8 kg
Standard gun*	273 199 0780	Standard gun	3.5 kg
Earth Device*	273 190 1360	Earth Device	1.1 kg
Battery charger ELITE*	273 199 5020	Battery charger ELITE	3.0 kg
Attaché Case*	273 190 4680	Attaché Case	3,3 kg
Easybond MKII Power control Unit	273 199 5610	Easybond MKII unit complete	18.8 kg
EB2 battery kit, inc-3xBattery and Bag**	273 199 5630	EB2 battery kit	15.3 kg
EB2 Pin brazing enclosure**	273 199 5650	EB2 Pin brazing enclosure	3.5 kg
EB2 Re-chargeable Battery Pack	273 199 5640	EB2 Battery Pack	15.8 kg
EB2 battery kit, (3xBattery and Bag)***	273 199 5630	EB2 battery kit	15.3 kg
EB2 Charge adaptor***	273 199 5620	EB2 Charge adaptor	0.5 kg
Grinder 42V	273 199 0680	Grinder 42V	2,3 kg
Grinding burr	273 190 1370	Grinding burr	0.04 kg
In Car Battery Charger VEPAC	273 199 5040	In Car Battery Charger VEPAC	1.5 kg
Welding generator compatible gun	273 199 0240	Welding generator gun	3.5 kg

*** Included when purchasing part number 273 199 5660, ** Included when purchasing part number 273 199 5610, ***Included when purchasing part number 273 199 5640**

Easybond Pin Brazing Equipment Spares and Service

A full set of spare parts for pin brazing equipment is available off the shelf for immediate despatch.

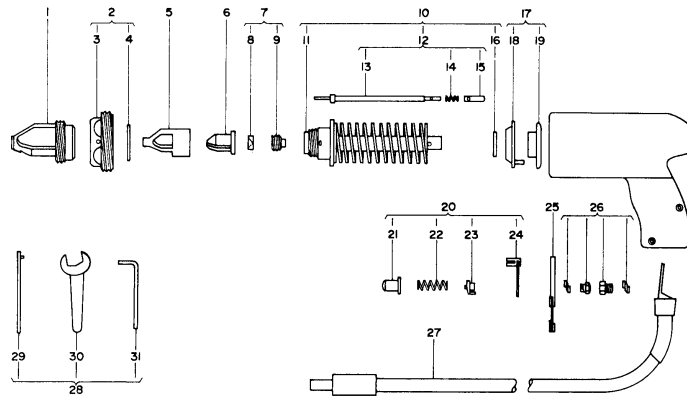

Brazing Gun spare parts list.

Item No	Part No	Description
1	270 074 8150	Ferrule Holder for 8mm direct brazing pins
	273 100 0560	Ferrule Holder for M8 threaded brazing pins
	273 100 1240	Ferrule Holder for M10/M12 threaded brazing pins
2	273 100 0840	Front Piece complete with locking ring
4	2700748160	Locking Ring
5	270 071 5600	Pin Holder for 8mm direct brazing pins
	273 100 0550	Pin Holder for M8 threaded brazing pins
	273 100 3870	Pin Holder for M10 threaded brazing pins
	273 100 1230	Pin Holder for M12 threaded brazing pins
6	2700715610	Spark Shield

Item No	Part No	Description
10	273 190 1190	Centre Piece Complete
12	273 190 0580	Ejector Rod Complete
16	270 071 5340	Remanence Washer
17	273 190 0590	Conductor Ring and Insulating Ring
20	273 190 600	Trigger Assembly
25	270 071 5700	Contact Arm
26	273 190 0110	Contact Set Complete
27	273 190 1310	Cable 35mm sq 1.7m long
28	273 190 0610	Tool Kit

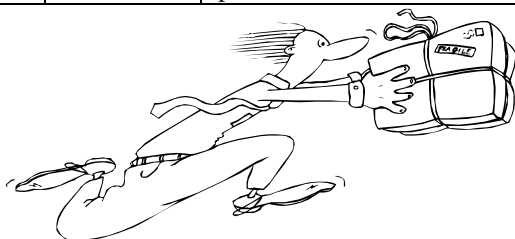

We offer a fast and efficient equipment refurbishment / repair service using genuine spare parts fitted by expert technicians. Most repairs can be completed within a few days keeping expensive downtime to a minimum.

Easybond Reach System (EBRS)

**A technique of making sound retrofit electrical connections to buried pipelines,
without the need for major Excavation.**



Safe, Fast, Economical

Specially designed to be compatible with the BAC Easybond range of pin brazing units, the Easybond Reach system (EBRS) comprises a special pin brazing gun with a purpose designed brazing tool that attaches to a fully adjustable (1.6m to 2.5m) hollow extension tube constructed of aluminium. To reach the buried pipe all that is required is a core-drilled hole (as little as 200mm diameter) down to the pipe where the connection pin needs to be brazed. The system also includes a device for local pipe coating removal and cleaning in the area to be bonded to ensure a good braze. Triggering of the device is controlled via a special manually controlled switch mounted onto the battery unit.

We reserve the right to make technical changes.



Part Number	Description
273 199 5100	EBRS Complete
273 199 5060	Gun and Lance
273 199 5070	Trigger Device
273 199 5080	Earth Device
273 199 5090	Adaptor kit for Standard Grinder

We reserve the right to make technical changes.

Digital Electronic Pin Brazing Unit PFBG-02 (BB2)



BB2 is a machine suitable for larger maintenance or installations. One person can easily carry the equipment and The BB2 pin brazing process is electronic, therefore **FUSELESS PINS** can be used. It is however possible to use brazing pins with a fuse wire. BB2 is programmed for the adjustments F, B, G and X, This adjustment prefix is stated on the package label of the brazing pin, and is controlled manually via a switch on the control panel of the unit. The capacity is approx. 50+ brazes with the smallest type of brazing pin, and it can easily be increased by a battery charger mounted in a vehicle, the batteries being charged up during transportation between workplaces. When alternating between charging and brazing it is possible to increase the capacity up to 5 times during a working day. The batteries are sealed to prevent acid spill.

Description and Part No. PFBG-02 (BB2)

Pin brazing unit	273 199 0760
Case, attaché	273 190 4680
Battery HP, 3 pcs per set	273 900 1810
Standard gun	273 199 0570
Earth device	273 190 1360
Extension gun	273 199 0640
Angle gun	273 199 0670
Grinder 42V, model small	273 199 0680
Grinding burr	273 190 1370
Battery charger	273 199 5020
Battery Charger for vehicle	273 199 5040

Weights:

PFBG-02 with batteries	23,8 kg
PFBG-02 without batteries	9,7 kg
Case, attaché	3,3 kg
Battery HP, 3 pcs per set	4,9 kg
Standard gun	4,0 kg
Earth device	1,1 kg
Extension gun	4,5 kg
Angle gun	5,2 kg
Grinder 42V, model small	2,3 kg
Grinding burr	0,04 kg
Battery charger	3,0 kg
Battery Charger for vehicle	1,5 kg

HP = High performance

We reserve the right to make technical changes

A full set of spare parts for pin brazing equipment is available off the shelf for immediate despatch.

CORROSION CONTROL

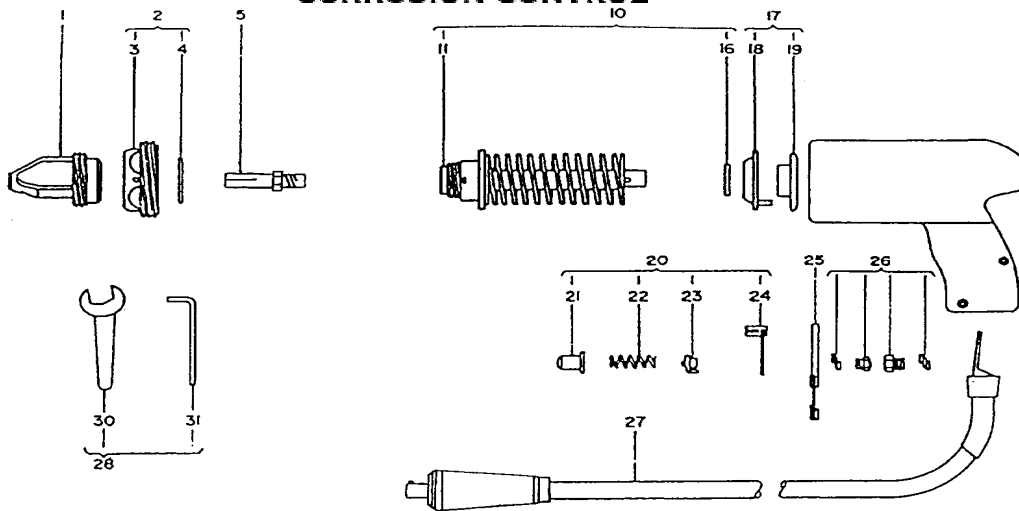
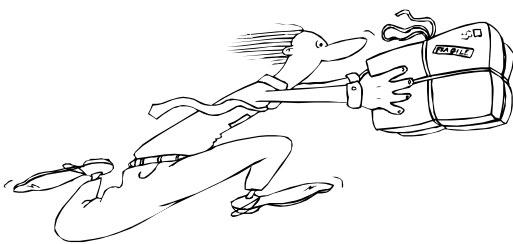

Fig 5

Item No	Part No	Description	Item No	Part No	Description
	273 199 0570	Standard Electronic Brazing Gun		273 190 1420	Pin Holder for M12 threaded brazing pins
1	270 074 8150	Ferrule Holder for 8mm direct brazing pins	10	273 190 1430	Centre Piece Complete
	273 100 0560	Ferrule Holder for M8 threaded brazing pins	16	270 071 5340	Remanence Washer
	273 100 1240	Ferrule Holder for M10/M12 threaded brazing pins	17	273 190 0590	Conductor Ring and Insulating Ring
2	273 100 0840	Front Piece complete with locking ring	20	273 190 0600	Trigger Assembly
4	270 074 8160	Locking Ring	25	270 071 5700	Contact Arm
5	273 190 0490	Pin Holder for 8mm direct brazing pins	26	273 190 0110	Contact Set Complete
	273 190 1400	Pin Holder for M8 threaded brazing pins	27	273 190 1310	Cable 35mm sq 1.7m long
	273 190 1410	Pin Holder for M10 threaded brazing pins	28	273 190 1440	Tool Kit



We offer a fast and efficient equipment refurbishment / repair service using genuine spare parts fitted by expert technicians. Most repairs can be completed within a few days keeping expensive downtime to a minimum. We reserve the right to make technical changes